

AirROC T35 and D50

Tophammer and Down-The-Hole drill rigs





Pioneer strength and agility

AirROC T35, the tophammer medium size air drill rig, with its unique VL 140 pneumatic rock drill is the pathfinder opening new horizons of drill efficiency. AirROC D50 is a Down-The-Hole drill

rig, which can work with ease on steep grades and the roughest terrain. These machines are suitable for limestone, aggregate quarries and surface mining applications.

⊕ Main benefits

The unique VL 140 rock drill takes up to 102 mm (4") hole diameter

Application compatibility due to interchangeability between tophammer and Down-The-Hole (DTH)

Transportation is made easier by fixed length boom and drill width

Rugged efficiency

Construction work or fine quarry drill work, these rugged drill rigs navigate steep climbs and rough terrain efficiently. The Atlas Copco air compressor ensures fast and efficient drilling, and keeps going on for longer working hours. Servicing, when needed is a quick one-man task.



+ Effectiveness built in

Tramming is effected by features like independent 11 hp piston air motor per track and an enclosed gear drive. Forward or reverse movement, the spring applied disc brakes always remain effective. Hydraulically cushioned track oscillation absorbs the shock loads and the oscillation may be locked out when a solid setup for drilling is desirable. A simple trap door centralizer is accessed at the touch of a foot.



+ Unique rock drill and rotation units

The unique Epiroc VL 140 air rock drill with a new cycle and piston design has a positive effect on the drill efficiency. Down the hole tasks are covered by BRH rotation units or by the ARH rotation units depending on the drill hole size. The ARH unit works a planetary gearbox, driven by a high power air vane motor for bigger holes.



+ Easy control – ample power

Side mounted tramming controls provide easy access. During compressor towing a safety lockout switch blocks reverse motion. Hole collaring is made operator convenient by a fine feed regulator and prevents stuck steels. A piston type air feed motor drives a heavy roller chain, providing sufficient pullout power, and all the pull down ever need in drilling.

A comprehensive service offering

Even the best equipment needs to be serviced regularly to make sure it sustains peak performance. An Epiroc service solution offers peace of mind, maximizing availability and performance throughout the lifetime of your equipment. We focus on safety, productivity and reliability.

By combining genuine parts and an Epiroc service from our certified technicians, we safeguard your productivity – wherever you are.



Technical specifications

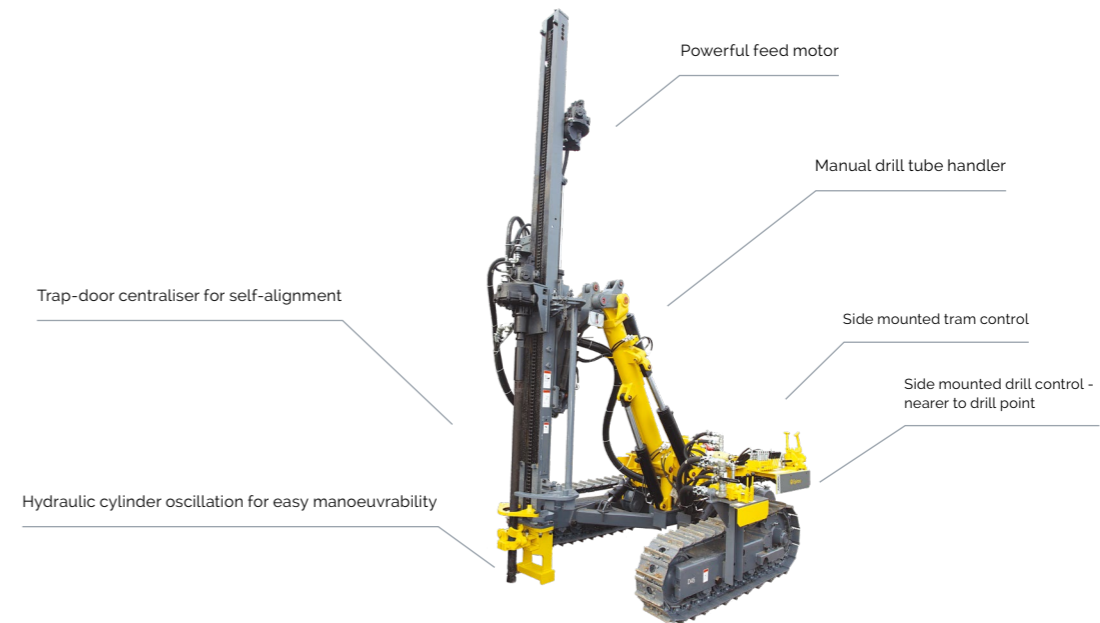

Main components

- Pneumatic operated hydraulic power pack for hydraulic cylinders
- Pneumatic operated chain feed for 3 000 mm (10 ft.) drill tubes for AirROC D50
- Pneumatic powered traction motors
- Pneumatic operated chain feed for 3 000-3610 mm (10-12 ft.) extension rods for AirROC T35
- Track chains with 260 mm track shoes
- Manual drill steel support
- Hydraulic track oscillation
- Side-mounted drilling control panels
- Towing hook
- Side-mounted tramming and positioning controls
- 20 Bar for AirROC D50 air line and oil lubrication system
- Extra air outlet for cleaning or running air tools (e.g. grinding equipment)
- Standard boom system

Quick facts

Main application:	Limestone quarries, surface mining, aggregate quarries
Drilling method	Down the hole, Tophammer
DTH hammer	QL 40, QL 50 STD, COP 44
Rock drill	VL 140
Drill steel	DTH 76 mm, 89 mm, 102 mm, Tophammer T38, T45
Hole diameter	DTH 105-140 mm, Tophammer 64-102 mm
Maximum hole depth	DTH 29.4 m, Tophammer 15 m

Carrier

	Metric	US
Tramming speed, max	3.0 km/h	2.86 mph
Traction force, max	32.5 kN	7 306 lbf
Track oscillation	±10°	±10°
Ground clearance	254 mm	10"
Hill climbing ability 30 deg max. (w/o compressor)		

Volumes

	Metric	US
Hydraulic oil tank	57 l	15 gal
Hydraulic system, total	62 l	16.4 gal
Traction gear	2 l	0.53 gal
Lubrication tank (HECL)	76 l	2 gal

All performance parameters above are valid for 7 bar air pressure

Hole range

Drill Rig	Pipe size		Recommended hole range	
	Metric	US	Metric	US
AirROC T35	38, 45 mm	1 ½", 1 ¾"	64 -102 mm	2 ½" - 4'
AirROC D50	76, 89, 102 mm	3", 3 ½", 4"	105 -140 mm	4 ¼" - 5 ½"

Steel feed

AirROC T35, AirROC D50 – Pneumatic-driven chain feed		
	Metric	US
Feed extension	1 219 mm	48'
Feed rate, max	0.25 m/s	49.2 ft/min
Feed force, max	21 kN	4 720 lbf
Tractive pull, max	14 kN	3 372 lbf
Total length	5 750 mm	226.3'
Travel length	4 250 mm	167.3'

Air consumption and compressor recommendation

Component	Production country	Operating pressure (bar)	Air consumption (l/sec)	AirROC T35	AirROC D50								
					10.3 bar		13.8 bar		17.2 bar				
Tophammer													
VL 140	India	7	250	250	250								
Flushing													
Drill steel T30				70									
Drill steel T45				80									
DTH hammers													
TD 35	Sweden/India	10.3/13.8/17.2	103/135/163		103				135			163	
QL 40	USA/India	10.3/13.8/17.2	116/160/206			116			160			206	
COP 44	Sweden/India	10.3/13.8/17.2	95/135/182			95			135			182	
COP 54	Sweden	10.3/13.8/17.2	140/200/275				140			200		275	
Chain feed													
DD6 FM1+CMFM	India	7	52	52	52	52	52	52	52	52	52	52	
Rotation unit													
BRH/ARH	India	7	61		61	61	61	61	61	61	61	61	
Total air consumption excl. DCT				372	382	216	229	208	253	248	273	248	313
Compressor recommendation													
XAMS 426/926 (Mercedes/CAT)	7	416	x	x									
XAH 210 (Cummins)	10.5	214			(x)		(x)	(x)					
XAHS 675 (Cummins)	12	318			x	x	x	x					
XXAVS 600 (Cummins)	14	283							x	(x)	(x)	x	
XAHS 236/506 (Mercedes/CAT)	12	235			(x)	(x)	x						
XAHS 306/676 (Mercedes/CAT)	12	317			x	x	x	x					
Dust collector													
DCT 60	India	6	25	25	25								
DCT 140E	India	6	65			65	65	65	65				
Total air consumption incl. DCT				397	407	281	294	273	318				
Compressor recommendation													
XAMS 426/926 (Mercedes/CAT)	7	416	x	(x)									
XAHS 675 (Cummins)	12	318			x	(x)	x	x					
XAHS 306/676 (Mercedes/CAT)	12	317			x	(x)	(x)	(x)					
XAHS 416/836 (Mercedes/CAT)	12	416							x				

Note (x) on the margin. Air consumptions given are required volume for the respective hammer/drifter/DCT to function – additional volume of air required for flushing can vary. This depends on drilling depth and rock formation.

Selection of options

- Mechanical hole inclination instrument, type ROC ANGLE
- Water injection system with pneumatic pump
- Water mist flushing system with pressurised tank
- Dust collector DCT 140 with rubber dust outlet - supplied with dust collection skirt or disc for AirROC D50
- Manual Rod Changer (2 Rods) for Air ROC D50
- Dust collector DCT 60 with rubber outlet for AirROC T35 - supplied with dust collector skirt or disc

Transport dimensions

Tramming position	Metric	US
Height	2 250 mm	88.6'
Length	5 750 mm	226.4'
Transportation position		
Height	2 430 mm	95.7'
Length	5 750 mm	226.4'
Width	2 480 mm	97.6'
Weight (Standard unit excluding all options and drill steel)		
AirROC T35 and D50	4 800 kg	10 582 lb

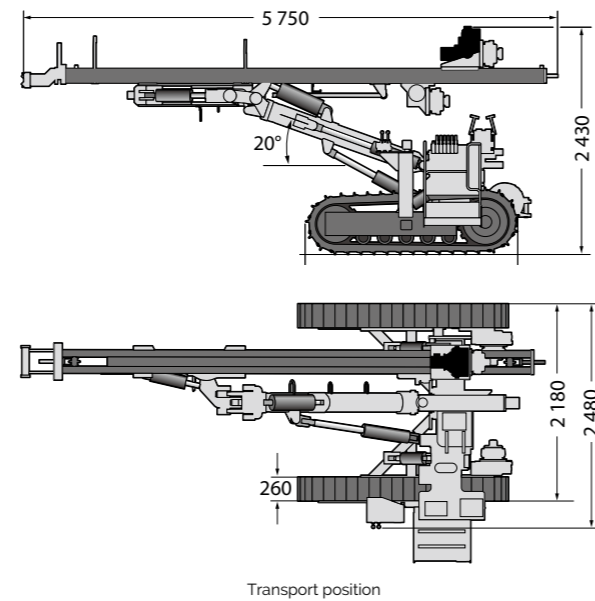

Transport position

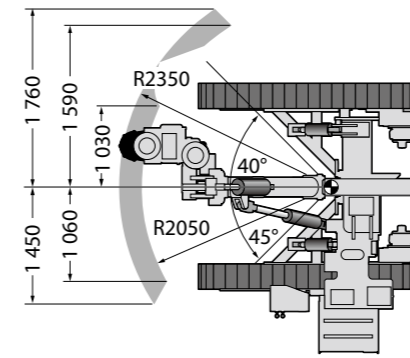

Horizontal reach (mm)

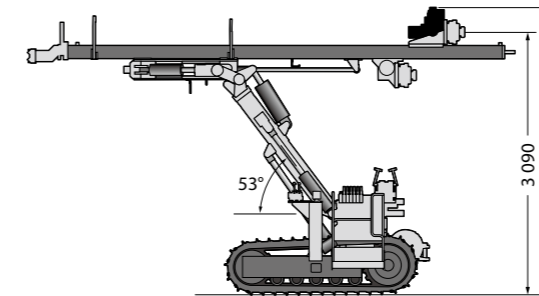

Maximum horizontal reach (mm)

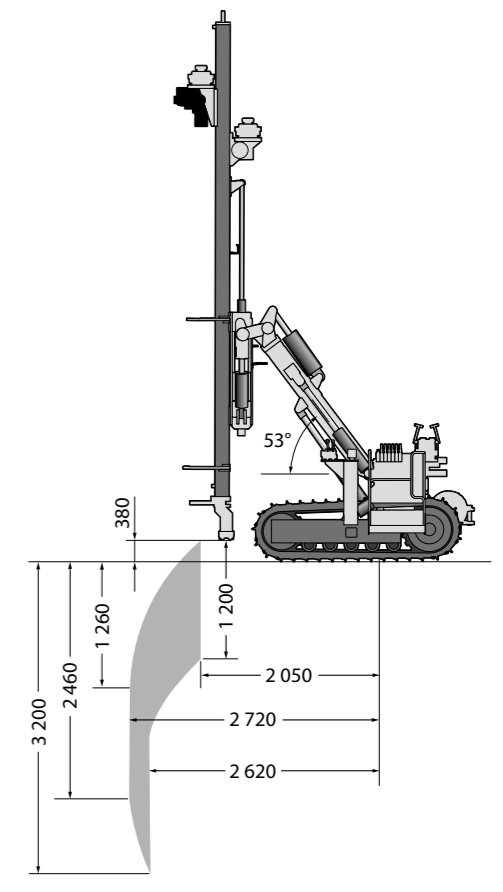

Vertical coverage area (mm)

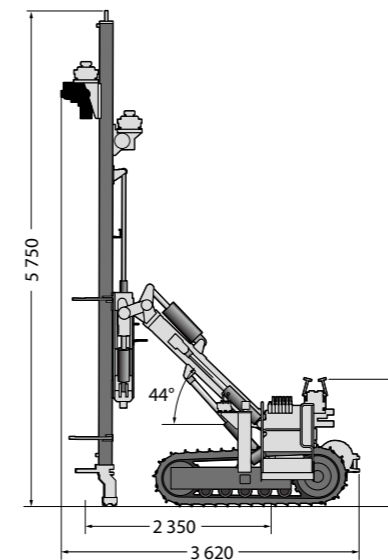

Feed vertical on ground

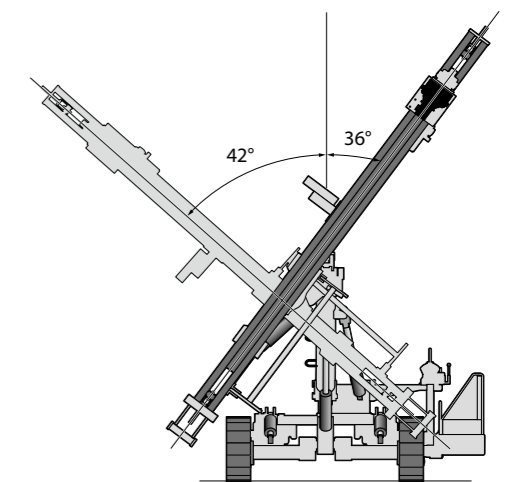

Factory setup

United in performance. Inspired by innovation.

Performance unites us, innovation inspires us, and commitment drives us to keep moving forward. Count on Epiroc to deliver the solutions you need to succeed today and the technology to lead tomorrow.
epiroc.com

